

REFRIGERATOR / FREEZER GUARD M705E™

You need to collect data of the temperature sensitive contents of your refrigerators and freezers.

The Refrigerator/Freezer Guard is the perfect solution!

The Refrigerator/Freezer Guard monitors temperature, doors, water and power.

The Refrigerator/Freezer Guard can also email or text (USA only) you if the temperature goes out of limits, a door is left open, or water is detected with our free software with the help of our Data Capture software.

Features

Maximum temperature sensor range: -328°F to 392°F, -200°C to 200°C

Factory calibrated range -149°F to 78°F (-100°C to 25°C) to less than 1 degree.

Program high and low temperature limits and an out of limits time delay for each sensor.

The four dry contact inputs prevents accidental temperature changes by generating an alarm if a refrigerator or freezer door has been left open, water is detected on the floor, or any other relay closure or opening.

Program the Refrigerator/Freezer Guard easily and conveniently with our Data Capture software.

Programming can be password protected.

The buzzer and optional alarm relay output can be used to alert onsite staff when a problem occurs so they can take immediate action.

View real time refrigerator/freezer status on the LCD display.

The twenty four hour rechargeable battery backup allows the temperature to be monitored during a power loss.

Low battery indicator! Will alert via email or text if battery ever gets low. Data Capture software required.

Maintain temperature records in electronic format with the M705E.

The Refrigerator/Freezer Guard makes solving problems easy:

Receive an email or text message if the temperature goes out of limits, a door is left open, or water is detected. Data Capture software required.

The Alarm Reminder Time Delay repeats the alarm notification messages if a problem still exists after this programmable time has expired.

Specifications

Calibrated Measuring Range:	-149°F to 78°F, -100°C to 25°C (0.1° resolution)
Full measuring Range:	-328°F to 392°F, -200°C to 200°C
Accuracy	+/- 1.0°F
Temperature Sensor Type:	RTD: 2 wire, 1000 ohm, Platinum, .00385 TCR, bullet style
Dry Contact Inputs:	4 @ 5VDC 10ma source
Outputs:	
Optional Relay:	24VDC 120mA load max for signals only
Alarm Buzzer:	85 dB
Power Requirements:	120VAC at 50/60 Hz wall mount transformer (included)
Electrical Connections:	2 Pluggable 12 position terminal blocks
Enclosure Material:	Flame retardant ABS plastic, 94-5VA
Dimensions:	Enclosure: 5.0" x 7.5" x 1.75" (W x L x H) Keyhole Mounting Holes: 3.937" between holes
Ambient Operating Conditions:	32°F to 125°F
Shipping Weight:	3 lbs
Agency Compliance:	Power supply is UL listed

Wiring Diagram (side view of enclosure)

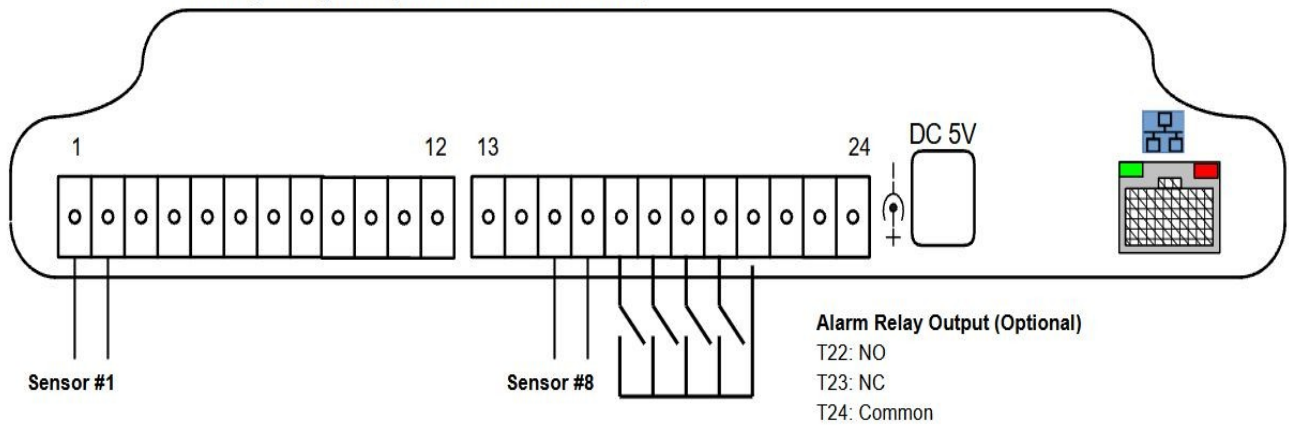

Temperature Sensors (RTD Sensors)

Temperature sensors are located in the refrigerator, freezer, or cooler and connected to the Refrigerator/Freezer Guard via a two conductor cable. Locate the sensors to yield an average temperature.

Avoid placing sensors in air streams. The wiring can be extended as required. For distances under 250 feet using 22 AWG two conductor cable or CAT5e cable is recommended. For distances over 250 feet, a larger wire is recommended. Please contact sales for advice on long cable runs.

Dry Contact Inputs

Connect normally closed magnetic or limit switches to refrigerator/freezer doors. Any number of magnetic switches can be connected in series. The inputs source 5 VDC at 10ma (see the manual for details on programming this input). Water sensors are also compatible.

REFRIGERATOR / FREEZER GUARD MODEL M705E WITH DATA CAPTURE SOFTWARE

You need to receive alarm emails and text messages to notify you if your Refrigerator/Freezer Guard detects a problem.

You need to maintain a log file of the data collected from your Refrigerator/Freezer Guard. With the M705E Refrigerator/Freezer Guard and a PC you can set up a complete monitoring and alarming solution. A PC running our Data Capture software can send emails and sms messages detailing the problem so you can quickly take corrective actions to avoid an expensive loss of property.

The Data Capture software automatically collects and maintains a log of the data obtained from your Refrigerator/Freezer Guard.

Features

View real time data.

View historical data.

Automatically sends alarm emails (via the computer) to key personnel that specifies the exact location and cause of the problem.

Maintains secure data log files for all data.

Easily create and print graphs over specified time periods for any data.

Specifications

LAN:	Ethernet 10Base-T or 100Base-TX (Auto-Sensing)
Transport Protocol:	TCP/IP, UDP
Connector	RJ45
EMI Compliance:	Radiated & conducted emissions - complies with Class B limits of EN 55022:1998 Direct & Indirect ESD - complies with EN55024:1998 RF Electromagnetic Field Immunity - complies with EN55024:1998 Electrical Fast Transient/Burst Immunity - complies with EN55024:1998 Power Frequency Magnetic Field Immunity - complies with EN55024:1998 RF Common Mode Conducted Susceptibility - complies with EN55024:1998
LED Indicators:	10Base-T connection 100Base-TX connection Link & activity indicator - Full/half duplex
Ambient Operating Conditions:	32°F to 125°F