

# Computer Room Guard

Models VM500-8, VM500-8-DCP-E

Manual and Installation Instructions

---

For units purchased since March 2006

<b>Index</b>	<b>Page</b>
Installation, Wiring Diagram	3-5
Accessing the Computer Room Guard	6
Programming the Inputs	7
Recording Zone ID Messages	7
Programming Zone Temperature and Humidity Limits	7, 8
Programming Zone Callout Time Delays	8, 9
Programming Temperature and Humidity Corrections	9, 10
Programming the Power Outage Alarm Time Delay	14
Programming the Autodialer Functions	11
Programming Telephone/Pager Numbers	11
Recording a Personal Identification Message	12
Programming a Local Identification Number for Pagers	12
Programming the Number of Rings to answer on	12
Programming PIN numbers	13
Programming Reminder Calls	13
Programming Repeat Warning Messages	14
Programming the Callout Time Delay	14
Using the Computer Room Guard	14
Checking Values	14,16
Clearing High and Low Data	15
Understanding the Display	16-17
Frequently Asked Questions	18
When does the VM500-8 make emergency calls?	18
When is a sensor in alarm condition?	18
What happens during a call to a pager?	19
How can I connect multiple devices on one line	19
Batteries / Optional Batteries	20
Troubleshooting	20
Advanced Network Setup	21
FCC and Warranty Information	22-23

## General Description

The Computer Room Guard model VM500-8 is a complete multi-room environmental monitor and alarm with a built in auto-dialer to alert key personnel with a phone call or pager message. The Computer Room Guard monitors the temperature and humidity in up to four rooms, monitors for standing water and power loss.

Up to four (4) Temperature (ACI/1K-2W-R) or Temperature and Humidity (ACI/1K-2W-RH3-R) sensors can be connected to the Computer Room Guard. Up to four (4) Water sensors (WTR-1040) can also be connected to the Computer Room Guard.

## Installing the Computer Room Guard

- 1 Mount the Computer Room Guard in a location with access to power and a telephone line using the included hardware. For ease of wiring, the terminal blocks on the Computer Room Guard can be removed by pulling them straight out.
- 2 Mount the ACI/1K-2W-R and/or ACI/1K-2W-RH3-R sensors in the desired locations following the instructions in the manual.
- 3 Mount the optional WTR-1040 water sensor with the steel contact points flat on the ground with a single screw through the center of the sensor in the desired location.
- 4 Wire each sensor to the Computer Room Guard. See pages 4-5.
- 5 Sensors must be connected prior to powering on the Computer Room Guard or they will not be detected!**
- 6 Connect the phone line to an active phone jack.
- 7 Plug in the wall mount transformer into a power socket.
- 8 Use of a surge suppresser for the phone line and the wall mount transformer is recommended.
- 9 Connect the power supply jack to the Computer Room Guard.
- 10 Move the power switch located to the left of terminal blocks to the "1" position. The display will turn on and display temperature and humidity readings for each connected sensor.

### For VM500-8-DCP-E units:

#### Download the Data Capture software from:

<http://www.temperatureguard.com/datacapture>

#### Set the IP address of your Temperature Guard

Run the Temperature Guard IP Address Setup Program. See the IP Setup Manual for details on using this program. See the troubleshooting section of this manual if you experience difficulties.

#### Collect data from your Temperature Guard

Please see the Data Capture Manual for detailed instructions on using the Data Capture Program.

**Computer Room Guard Wiring Diagram (side view of enclosure)**  
**Terminal Block Designations (LAN is on DCP-E model)**

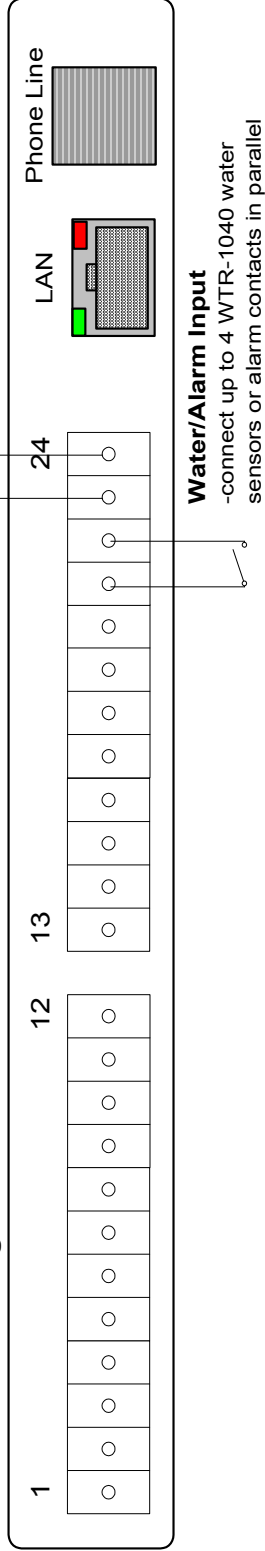

**ACI/1K-2W-RH3-R TEMPERATURE AND HUMIDITY SENSOR WIRING**

4

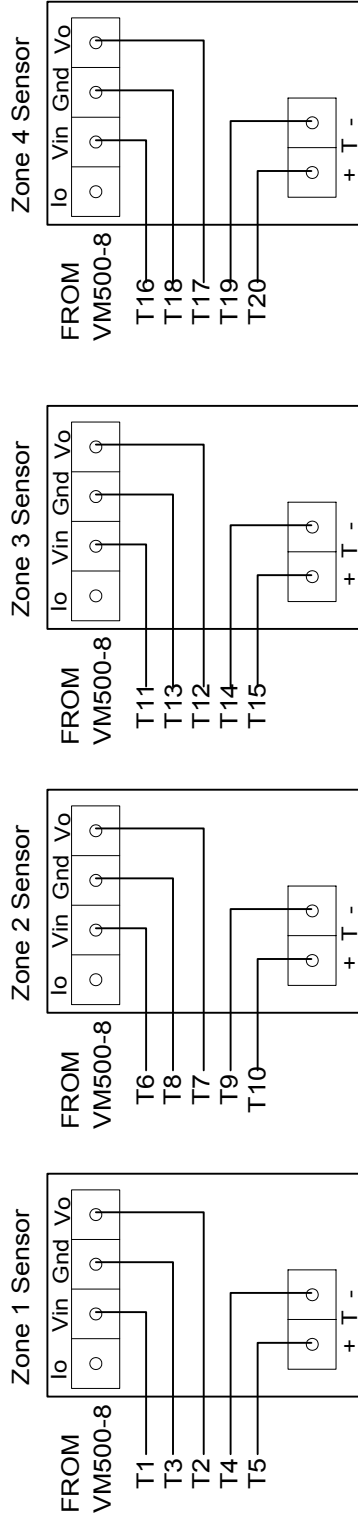

## ACI/1K-2W-R TEMPERATURE SENSOR WIRING

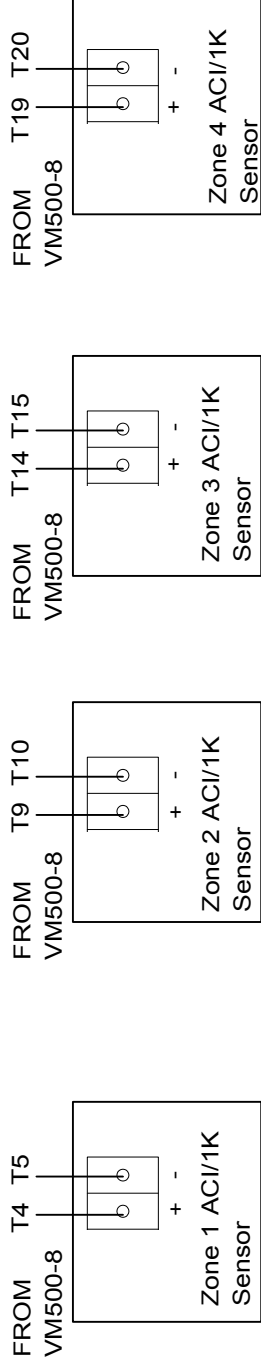

### Installing the ACI/1K-2W-RH3-R Temperature and Humidity Sensor and the ACI/1K-2W-R Temperature Sensor

The sensors should be placed away from excessive moisture, corrosive fumes, vibration, or extremely high temperatures. The base of the housing was designed to mount over a standard 2" X 4" junction box or flush to the wall.

- 1) Turn off the **VM500-8** and remove the power from the device.
- 2) Mount the unit on an indoor wall, approximately 4 to 6 feet above the floor.
- 3) Make sure the unit receives adequate airflow.
- 4) Use a 5 conductor cable for an ACI/1K-2W-RH3-R or a 2 conductor cable for an ACI/1K-2W-R, 18-22awg to connect the sensors to the VM500-8.
- 5) Snap the cover into position.
- 6) Turn out the (2) 1/16" Allen screws located at the bottom of the enclosure until the cover cannot be removed.
- 7) Verify wiring before applying power.

### Installing the WTR-1040 Water Sensors

- 1) Locate the sensor in the desired area to monitor for standing water. The four steel contact points must be against the floor and the black side facing up.
- 2) For a permanent installation, cut out the thin plastic film in the center of the sensor and the bolt the sensor to the floor through the hole.
- 3) Run the sensor wire to the monitor and connect one conductor to terminal 21 and the other to 22. Repeat for additional sensors.

## Accessing the Computer Room Guard

- 1 From another phone line dial the number where the Computer Room Guard is located. The device will pick up after the programmed number of rings (Factory default is 1).
- 2 When prompted, enter the 4-digit PIN number (Factory default PIN number is 0000).
- 3 You will hear the Main Menu options:

Main Menu	
Option	Function
1	Status
2	Set Limits
3	Program
#	<i>Repeat Warning Message (if any input is in alarm condition)</i>
0	Exit (Hang Up)

## Programming Temperature / Humidity Inputs

Each room/zone has seven (7) programmable parameters.

**Zone ID Message.** The Room/Zone ID Message is a recordable 2 second message that is played when the status of the zone is being reported.

**Zone Low and High Temperature limits.** The low and high temperature limits are programmed in degrees. When a zone's temperature exceeds either the high or low limit for longer than the programmed time delay, the Computer Room Guard will begin making calls.

**Zone Temperature callout time delay.** A zone's temperature must be out of limits for greater than the callout delay time before the Computer Room Guard will begin making telephone calls.

**Zone Low and High Humidity limits.** The low and high humidity limit values are programmed in % RH. When a zone's relative humidity exceeds either the high or low limit for longer than the programmed time delay, the Computer Room Guard will begin making telephone calls.

**Zone Humidity callout time delay.** A zone's humidity must be out of limits for greater than the callout delay time before the Computer Room Guard will begin making telephone calls.

### **Programming Sensor Parameters**

#### **1. Accessing the Sensor Configuration**

- a) From the Main Menu, press 2 to Set Limits
  - ▶ The "Full Access" PIN will be requested if the "Confirmation Only" PIN was entered initially. If the correct "Full Access" PIN is not entered, the Computer Room Guard will hang up.
- b) You will hear "*Enter Zone*"
- c) Enter the zone you want to program (1-4)
  - ▶ To return to the Main Menu press 0
- d) Proceed to step 2.a.

#### **2. Recording the Zone ID Message**

- a) You will hear "*Zone x message is...*" and the current ID message. If the current zone's ID message has not been programmed you will hear a brief period of silence.
- b) You will hear "*Press 1 to change*"
- c) Press **1** to change the message
  - ▶ Press 2 to skip and proceed to step 2.a or press 0 to stop programming this zone and return to step 1.b
- d) You will hear a tone
- e) Begin speaking after the tone. The Computer Room Guard will record for about 2 seconds
- f) After 2 seconds you will hear the tone again, marking the end of your message
- g) You will hear the message you recorded.
- h) Proceed to step 2.a

#### **2. Programming the Lower and Upper Temperature Limits**

- a) You will hear "*Zone x lower temperature limit is*" and the current low temperature limit for that zone (i.e. *40 degrees*)
- b) You will hear "*Press 1 to change*"
- c) Press **1** to change the limit
  - ▶ Press 2 to skip and proceed to step 3.g or press 0 to stop programming this zone and return to step 1.b
- d) You will hear "*Enter number then press pound*"
- e) Enter the value then press **#**.
  - ▶ Acceptable range 32F to 120F
- f) You will hear the value you just entered (i.e. *55 degrees*)
- g) You will hear "*Zone x upper temperature limit is*" and the current high temperature limit for the selected zone (i.e. *85 degrees*)

- h) You will hear "*Press 1 to change*"
- i) Press **1** to change the limit
  - ▶ Press 2 to skip and proceed to step 3.a or press 0 to stop programming this zone and return to step 1.b
- j) You will hear "*Enter number then press pound*"
- k) Enter the value then press **#**.
  - ▶ Acceptable range 32F to 120F
- l) You will hear the value you just entered (i.e. *75 degrees*)
- m) Proceed to step 3.a

### **3. Programming the temperature callout delay time**

- a) You will hear "*Temperature alarm time delay is XX minutes press 1 to change*"
- b) Press **1** to make a change
  - ▶ Press 2 to skip and proceed to step 4.a or press 0 to stop programming this zone and return to step 1.b
- c) You will hear "*Enter number then press pound*"
- d) Enter the time delay in minutes (i.e. 15 for 15 minutes or 0 minutes for an immediate callout)
  - ▶ Acceptable range is 0 to 900 minutes
- e) You will hear the value you just entered
- f) Proceed to step 4.a

### **4. Programming the Lower and Upper Humidity Limits**

- a) You will hear "*Zone x lower humidity limit is*" and the current low humidity limit for that zone (i.e. *0 percent*)
- b) You will hear "*Press 1 to change*"
- c) Press **1** to change the limit
  - ▶ Press 2 to skip and proceed to step 5.a or press 0 to stop programming this zone and return to step 1.b
- d) You will hear "*Enter number then press pound*"
- e) Enter the value then press **#**.
  - ▶ Acceptable range 0% to 100%
- f) You will hear the value you just entered (i.e. *20 percent*)
- g) You will hear "*Zone x upper humidity limit is*" and the current high humidity limit for the selected zone (i.e. *100 percent*)
- h) You will hear "*Press 1 to change*"
- i) Press **1** to change the limit
  - ▶ Press 2 to skip and proceed to step 5.a or press 0 to stop programming this zone and return to step 1.b
- j) You will hear "*Enter number then press pound*"
- k) Enter the value then press **#**.
  - ▶ Acceptable range 0% to 100%

- l) You will hear the value you just entered (i.e. 70 percent)
- m) Proceed to step 5.a

#### **5. Programming the humidity callout delay time**

- a) You will hear "*Humidity alarm time delay is XX minutes, press 1 to change*"
- b) Press **1** to make a change
  - ▶ Press 2 to return to the Set Limits menu
- c) You will hear "*Enter number then press pound*"
- d) Enter the time delay in minutes (i.e. 15 for 15 minutes or 0 minutes for an immediate callout)
  - ▶ Acceptable range is 0 to 900 minutes
- e) You will hear the value you just entered
- f) Proceed to step 1.b

Repeat the steps 1 to 5 for each connected sensor/zone.

#### **Programming Temperature Corrections**

The Computer Room Guard allows the user to correct for temperature measurement errors due to sensor cable extension length. A calibrated temperature indicator must be used to obtain the actual temperature.

- a) From the Main Menu, press 2 to Set Limits
- b) You will hear "*Enter Zone*"
- c) Enter \*
- d) You will hear "*Enter zone to change*"
- e) Enter the number of the zone whose temperature sensor reading you wish to adjust.
- f) You will hear "*Temperature Change. Enter number then press pound*"
- g) Enter the actual temperature measured in the room, then press #. The temperature can only be corrected by  $\pm 10^{\circ}$  from the originally detected temperature. If larger corrections appear to be necessary, verify installation of temperature sensors and their placement.
- h) You will hear the newly corrected temperature and the corrected temperature will be displayed on the display.

#### **Programming Humidity Corrections**

The Computer Room Guard allows the user to correct for humidity measurement errors due to sensor cable extension length. A calibrated relative humidity indicator must be used to obtain the actual relative humidity.

- a) From the Main Menu, press 2 to Set Limits

- b) You will hear *"Enter Zone"*
- c) Enter #
- d) You will hear *"Enter zone to change"*
- e) Enter the number of the zone whose humidity sensor reading you wish to adjust.
- f) You will hear *"Humidity Change. Enter number then press pound"*
- g) Enter the actual humidity measured in the room, then press #.  
The humidity can only be corrected by  $\pm 10\%$  from the originally detected humidity. If larger corrections appear to be necessary, verify installation of sensors and their placement.
- h) You will hear the newly corrected humidity and the corrected humidity will be displayed on the display.

## Programming the Water/Alarm Input

The Water/Alarm input can be configured as a water sensor input or as a general purpose dry contact alarm input.

### **When the input is configured as water sensor input:**

The default time delay is 30 seconds. This value is not adjustable. The status of the input will be reported as "Water has/has not been detected"

### **When the input is configured as an alarm input:**

The default time delay is 0 minutes. This value may be programmed to any value between 0 and 900 minutes. The status of the input will be reported as "Alarm has/has not been detected"

### **Configuring the Water/Alarm Input**

- a) From the Main Menu, press 2 to Set Limits
- b) You will hear *"Enter Zone"*
- c) Enter 9
- d) You will hear *"Input is Water, press 1 to change"*
- e) Press 1 to change the input to alarm input mode.
- f) You will hear *"Input is Alarm, time delay is 0 minutes, press 1 to change"*
- g) Press 1
- h) You will hear *"Enter number then press pound"*
- i) Enter the time delay in minutes (i.e. 15 for 15 minutes or 0 minutes for an immediate callout)
  - ▶ Acceptable range is 0 to 900 minutes
- j) You will hear the value you just entered

## Programming the Autodialer Functions

### To access the Program Menu:

From the Main Menu, press 3

- ▶ The "Full Access" PIN will be requested if the "Acknowledge Only" PIN was entered initially. If the correct "Full Access" PIN is not entered, the Computer Room Guard will hang up.

Program Menu		
Option	Function	
1	Program Contact Telephone Numbers	
2	Program Local ID Number	
3	Record Unit ID Message	
4	Program Number of Rings	
5	Change "Full Access" PIN	
6	Program Reminder Calls	NOT SPOKEN
7	Program Repeat Warning Messages	NOT SPOKEN
8	Set Temperature Readout Units (°C or °F)	NOT SPOKEN
9	Program Power Outage Delay Time	NOT SPOKEN
*	Change Callout Time Delay	NOT SPOKEN
#	Change "Acknowledge Only" PIN	NOT SPOKEN
0	Exit (return to Main Menu)	

### Programming Contact Telephone/Pager Numbers

The Computer Room Guard stores up to four (4) contact telephone or pager numbers.

- From the Program Menu, Select **1** to set telephone numbers.
- You will hear "*Select contact one to four*"
- Select **1** for the first contact number, **2** for the second contact number, **3** for the third contact number, or **4** for the fourth contact number.
  - ▶ Press 0 to return to the Program Menu.
- You will hear "*Contact x is xxxxxx*" or "*Contact x is Empty, press one to change*"
- Press **1** to make a change or enter a telephone number.
- You will hear "*Enter number then press pound*"
- Enter the number, followed by a **#**
  - ▶ For pager numbers, enter \* as the first digit of the number
  - ▶ Enter the full telephone number (**1 + area code if necessary**)
  - ▶ If an extra delay between digits or after dialing is required, entering \* will

provide a two second delay. Do not enter \* for the first digit unless programming a pager number.

▶ Entering only the # key will erase the currently programmed contact telephone number.

- 8 You will hear the telephone number you just entered.
- 9 You will be prompted to select another contact to program.
  - ▶ Press 0 to return to the Program Menu.

### **Programming a Local Identification Number For Pagers**

The local ID number is printed on a pager's display, when calls are made to a pager. The ID number can be up to 20 digits long.

- 1 From the Program Menu, press **2** for the local ID
- 2 You will hear the programmed number or the Computer Room Guard will say "Empty"
- 3 You will hear *"Press one to change"*
- 4 Press **1** to make a change or **2** to return to the Program Menu
- 5 You will hear *"Enter number, then press pound"*
- 6 Enter the number, followed by a #
- 7 You will hear the number you just entered.
- 8 You will be automatically returned to the Program Menu

### **Recording a Personal Identification Message**

When the Computer Room Guard calls out, it first plays a 4 second personal identification message.

- 1 From the Program Menu, press **3** to record a message
- 2 You will hear the recorded message
- 3 You will hear *"Press one to change."*
- 4 Press **1** if you wish to make a change or press any other button to return to the Program Menu
- 5 You will hear a tone
- 6 Begin speaking after the tone. The Computer Room Guard will record for about 4 seconds
- 7 After 4 seconds you will hear the tone again, marking the end of your message
- 8 You will hear the message you recorded
- 9 You will be automatically returned to the Program Menu

### **Programming the Number of Rings**

The Computer Room Guard answers the telephone line after the programmed number of rings. Valid numbers of rings are 1 – 25.

- 1 From the Program Menu, press **4** to set the number of rings
- 2 You will hear the programmed number of rings
- 3 You will hear *"Press one to change."*
- 4 Press **1** if you wish to make a change or press any other button to return to the Program Menu
- 5 You will hear *"Enter number then press pound"*
- 6 Enter the number of rings, then press #
- 7 You will hear the number of rings you entered

8 You will be automatically returned to the Program Menu

#### **Programming the "Full Access" PIN Number**

The Computer Room Guard has a programmable "Full Access" 4-digit PIN number (0000-9999) to allow users to access the Set Limits option and Program sub-menu, and to confirm alarm conditions.

**PIN number must be 4 digits and must not include a # sign.**

- 1 From the Program Menu, press **5** to change the "Full Access" PIN
- 2 You will hear the programmed PIN number
- 3 You will hear "*Press one to change.*"
- 4 Press **1** to make a change or **2** to return to the Program Menu
- 5 You will hear "*Enter number*"
- 6 Enter a four digit number
- 7 You will hear the PIN number you just entered
- 8 You will be automatically returned to the Program Menu

#### **Programming the "Acknowledge Only" PIN Number**

The Computer Room Guard has a programmable "Acknowledge Only" 4-digit PIN number (0000-9999) to allow users to only to confirm alarm conditions and check status.

**PIN number must be 4 digits and must not include a # sign.**

- 1 From the Program Menu, press **#** to change the "Acknowledge Only" PIN
- 2 You will hear the programmed PIN number
- 3 You will hear "*Press one to change.*"
- 4 Press **1** to make a change or **2** to return to the Program Menu
- 5 You will hear "*Enter number*"
- 6 Enter a four digit number
- 7 You will hear the PIN number you just entered
- 8 You will be automatically returned to the Program Menu

#### **Programming a Reminder Call**

The Computer Room Guard can place "reminder calls" even after Emergency calls have been acknowledged. If reminder calls have been enabled and an alarm condition is still present after the Reminder Call Delay time, the Computer Room Guard will restart emergency call procedures.

- 1 From the Program Menu, press **6**
- 2 You will hear "Alarm Reminder is OFF, *Press one to change.*"
- 3 Press **1** if you wish to enable reminder calls
- 4 You will hear "Alarm Reminder is ON, callout time delay is XX minutes press **1** to change" (Min is 15m, max is 900m, default is 60 minutes) .
- 5 Press **1** to make a change
- 6 You will hear "Enter number then press pound"
- 7 Enter the time delay in minutes (i.e. 120 for 2 hours)
- 8 You will hear the value you just entered
- 9 You will be returned to the Set Limits Menu

#### **Programming Repeat Warning Messages**

During emergency calls the Computer Room Guard will **repeat** the local ID

message and warning conditions a programmable number of times (Default is 1 repetition)

- 1 From the Program Menu, press **7**
- 2 You will hear "Warning Reminder is 1"
- 3 You will hear "*Press one to change.*"
- 4 Press **1** to change or **2** to return to the Program Menu.
- 5 You will hear "Enter number then press pound"
- 6 Enter the number of times (0,1, or 2) that you would like the warning message repeated.
- 7 You will hear the value you just entered

#### **Set Temperature Readout Units (°C or °F)**

The Computer Room Guard can display and report temperature readings in degrees Celsius or Fahrenheit.

- 1 From the Program Menu, press **8**
- 2 You will hear "*Degrees is 32, press one to change*", indicating the temperature reading at freezing in its current mode. (Default is Fahrenheit)
- 3 Press **1** to switch to Celsius Temperature Readout, or **2** to return to the Program Menu.
- 4 Program Menu.
- 5 You will hear "*Degrees is 0*"
- 6 You will be automatically returned to the Program Menu

#### **Program Power Outage Delay Time**

The Computer Room Guard can delay a programmable amount of time before alarming due to a power outage. The default time is 5 minutes.

- 1 From the Program Menu, press **9**
- 2 You will hear "*Power callout time delay is 5 minutes press 1 to change*"
- 3 Press **1** to change, or **2** to return to the Program Menu
- 4 You will hear "Enter number then press pound"
- 5 Enter the time delay in minutes (i.e. 15 for 15 minutes or 0 minutes for an immediate callout, acceptable range is 0 to 120 minutes)
- 6 You will hear the value you just entered
- 7 You will be automatically returned to the Program Menu

#### **Changing the Callout Time Delay**

When a zone's temperature or humidity is out of limits or water is detected the Computer Room Guard will wait this programmable amount of time before making telephone alert calls. (Default 2 minutes)

- 1 From the Program Menu, press **\***
- 2 You will hear "Callout Time Delay is 2 minutes"
- 3 You will hear "*Press one to change.*"
- 4 Press **1** to change this setting, or **2** to return to the Program Menu.
- 5 You will hear "Enter number then press pound"
- 6 Enter the time delay in minutes (i.e. 60 for 1 hour, acceptable range 0 to 900 minutes)
- 7 You will hear the value you just entered
- 8 You will be automatically returned to the Program Menu

## Using the Computer Room Guard

### Checking Sensor Inputs Locally

See the section on "Interpreting the Display" on the following pages

### Checking Sensor Values with a Telephone Call

- 1 Call the Computer Room Guard
- 2 Enter your PIN number
- 3 From the main menu press **1**
- 4 You will hear "*Enter Zone*"
- 5 Enter the number of the zone/room you wish to hear about
  - ▶ To hear the status of the water sensor, enter 9.
- 6 You will hear a full status report for the zone.

### Checking Status Remotely with a Web Browser (VM500-8-DCP-E)

- 1 Open a web browser such as Internet Explorer.
- 2 Enter the IP address of the device for the URL address.
- 3 The status of all connected sensors will be displayed.

### Clearing High and Low Values Locally

High and low values can be cleared by holding the black push-button down for at least 5 seconds while that sensors high and low data is being displayed.

### Clearing High and Low Temperature / Humidity Values Remotely

- 1 Call the Computer Room Guard
- 2 Enter you PIN number
- 3 From the main menu press **1**
- 4 You will hear "*Enter Zone*"
- 5 Press **#**
- 6 You will hear "Enter Zone to Change"
- 7 Enter the number of the zone whose sensor data you wish to reset.

### Confirming Alarm Conditions Remotely

During callouts, the Computer Room Guard will prompt you to enter a PIN number, enter either the Full Access PIN or the Acknowledge Only PIN. If you have received a page or a voice mail message regarding an alarm condition that you wish to confirm. Simply call the Computer Room Guard and enter either the Full Access PIN or "1234", the Acknowledge Only PIN, The alarm relay will de-energize, and the Computer Room Guard will stop making callouts for the current alarm condition. **This action does not override the Reminder Call feature.**

### Confirming Alarm Conditions Locally

To confirm an alarm condition locally push the black button on the left side of the Computer Room Guard. The alarm relay will de-energize, and the Computer Room Guard will stop making callouts for the current alarm condition. **This action does not override the Reminder Call feature.**

## Interpreting the Display

### Start Up

When starting up, the Computer Room Guard checks each sensor input to verify that a sensor is connected.

If a sensor is connected and has a reading within range, "ok" will be printed next to that sensors label.

If a sensor is not connected or has a reading out of range, "n/c" will be printed next to that sensors label.

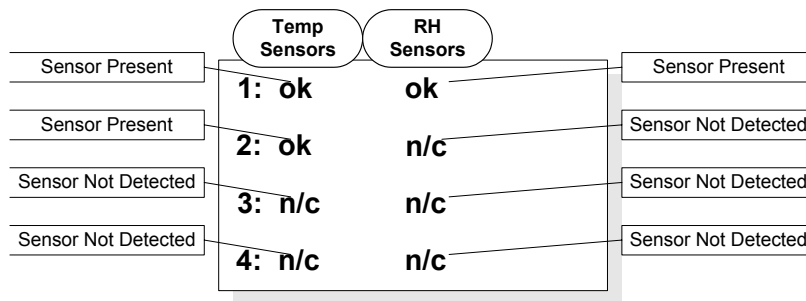

### Checking Sensor Values Locally

The Computer Room Guard displays all temperature and humidity data simultaneously and cycles through displaying the maximum and minimum values in the right side of the screen.

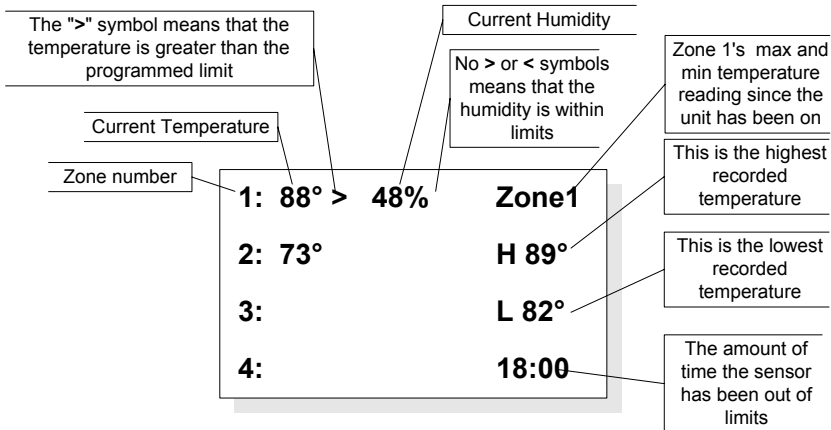

### Alarm Conditions

When an alarm condition occurs, the alarm relay and buzzer are activated and the Computer Room Guard waits 2 minutes before making callouts.

The time remaining before alarm callouts commence is displayed. During this time, onsite personnel can cancel the emergency by pressing the black alarm acknowledge button on the face of the Computer Room Guard.

1:	88° > 48%	CALL-
2:	73°	OUTS
3:		IN
4:		01:58

### Alarm Callouts

When the Computer Room Guard is making callouts, the status is displayed in the right side of the screen.

While the Computer Room Guard is making telephone calls, the display is not updated with new temperature readings.

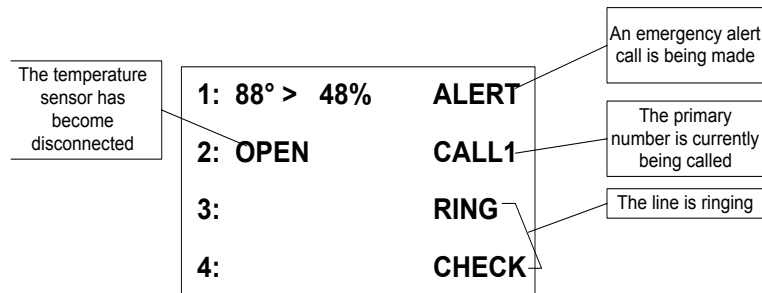

### Sensor Reading After Callouts

If the Computer Room Guard has called all programmed telephone numbers and not made contact, it will wait 20 minutes before attempting to callout again.

Periodically, the time before callouts resume will be displayed.

1:	88° > 48%	CALL-
2:	OPEN	OUTS
3:		IN
4:		17:25

## Frequently Asked Questions

### **When exactly does the Computer Room Guard callout?**

The Computer Room Guard will callout when any sensor or the power is in an alarm condition.

### **When is a sensor in alarm condition?**

When a Temperature Only, model ACI/1K-2W-R, or a Temperature and Humidity, model ACI/1K-2W-RH3-R, sensor has been out of limits for greater than the programmed time delay. Or, if a sensor opens after having been connected.

When water bridges two of the steel contact points of the WTR-1040 sensor for several seconds. The time response depends on the amount of water bridging the two contact points.

When the power has been out for greater than programmable power outage alarm time delay (default 5 minutes)

### **What happens when there is an alarm condition?**

- 1 The alarm relay and buzzer will be energized.
- 2 The Computer Room Guard will wait until the programmable Callout Time Delay period (default 2 minutes) expires to allow local personal to react to the alarm.
- 3 If the "Cancel Alarm pushbutton has not been pressed, the Computer Room Guard will begin calling all programmed telephone numbers starting with the primary number.
- 4 After the call has been answered, the Computer Room Guard will play a beep while it waits for a person to stop speaking or any outgoing message to stop.
- 5 The Computer Room Guard will play the Personal Identification Message.
- 6 The Computer Room Guard will report any alarm conditions (i. e. "*Zone 2 Temperature is 89 degrees..*").
- 7 The Computer Room Guard will ask for the PIN number.

Once the PIN number has been entered, the Computer Room Guard will not call again because the current alarm condition has been acknowledged, unless reminder calls have been enabled. If the correct PIN number is not entered within 4 seconds the Computer Room Guard will repeat the warning message. This warning message can be repeated up to 2 times by changing the

programmed value. See the **Programming Repeat Warning Messages** section.

### **How do I stop using a sensor**

To stop monitoring a particular sensor without causing an emergency phone call, perform the following steps:

- 1 Turn off the Computer Room Guard.
- 2 Remove the sensor you wish to stop using.
- 3 Turn on the Computer Room Guard.

### **What happens when the Computer Room Guard calls a pager?**

- 1 The Computer Room Guard will print the Local Identification number on the pager screen.
- 2 The Computer Room Guard will continue to call all programmed numbers until either:

A standard voice number is called and the PIN number is entered

OR

The alarm condition goes away

OR

The Computer Room Guard is called and the PIN number is entered

### **How can I connect the Computer Room Guard to a Phone Line which has a fax or answering machine connected to it**

Program the Computer Room Guard to answer after one more ring than the other device. This allows the other device to always answer first. To call and access the Computer Room Guard.

1. Dial the phone number
2. Hang up one ring before the other device answers.
3. Wait no longer than 30 seconds, then dial the phone number again.
4. The Computer Room Guard will answer.

For Example:

*A fax machine on the same line as the Computer Room Guard is set to answer after 4 rings. The Computer Room Guard is programmed to answer after 5 rings. To access the Computer*

*Room Guard, dial the number, let it ring three times, then hang up. Wait 20 seconds and call again. After two rings, the Computer Room Guard will answer.*

### **Optional 20 / 30 Hour Extended Batteries**

If your unit has been ordered with an extended battery, it is installed at the factory.

### **Standard and Extended Batteries**

**The batteries are constantly being trickle charged. Charging can take up to a week to reach full capacity. The battery is charging whenever the Computer Room Guard is on.**

## **Troubleshooting**

### **Verifying telephone communication**

To verify telephone communications, perform the following test.

- Using another phone line, call the Computer Room Guard and verify that it answers the phone.
- Verify at least one programmed telephone number.
- Hang up.
- Call the Computer Room Guard again
- Enter #999 for the PIN.
- Hang up
- The Computer Room Guard will perform a test call to your programmed telephone number (s). Do not enter your PIN if you would like the Computer Room Guard continue calling your programmed telephone numbers.
- Watch the display and note any messages present.

### **If the Computer Room Guard does not answer the phone**

Verify that the phone line is working. Connect a standard phone to the line intended for the Computer Room Guard. Verify that there is a dial tone.

Check that the phone line is plugged in securely.

Verify that the Computer Room Guard is powered up and the status light is blinking.

### **If the Computer Room Guard does not call out**

Perform the telephone communication verification procedure.

Connect a phone to the line intended for the Computer Room Guard. Verify that there is a dial tone.  
 Check that the phone line is plugged in securely  
 Verify that the Computer Room Guard is powered up and the status light is blinking  
 Verify that the Computer Room Guard is programmed correctly.  
 Call up the Computer Room Guard and verify the programmed phone numbers and limits.

**Verifying Network Connectivity (DCP-E units)**

When first plugging in the unit or connecting the LAN cable, the LEDs on the Ethernet jack will begin to blink first orange and then green. When fully powered up the left LED will be on steady green and the right LED will blink green.

Link LED (Left Side)		Activity LED (Right Side)	
Color	Meaning	Color	Meaning
Off	No Link	Off	No Activity
Amber	10 Mbps	Amber	Half-Duplex
Green	100 Mbps	Green	Full-Duplex

**Accessing advanced network setup**

To set either the Subnet Mask or Gateway Address the VM500-10 access the advanced network setup by entering:

[http://{Device IP Address}/ltx\\_conf.html](http://{Device IP Address}/ltx_conf.html)

Click on the “Server Properties” button.

Enter the Subnet Mask and/or Gateway Address and click “Update Settings”

**If the status web page does not display/load correctly (DCP-E units)**

Verify that you have the latest version of Java loaded on your computer. Go to [www.java.com](http://www.java.com) to download the latest version.

#### FCC PART 68 INFORMATION

This equipment complies with Part 68 of the FCC Rules. The FCC Part 68 Label is located on the bottom of the unit. This label contains the FCC Registration Number and Ringer Equivalence Number (REN) for this equipment. If requested, this information must be provided to your telephone company.

The REN is useful to determine the quantity of devices you may connect to your telephone line and still have all of those device ring when your telephone number is called. In most, but not all areas, the sum of the RENs of all devices connected to one line should not exceed five (5.0). To be certain of the number of devices you may connect to your line, as determined by the REN, you should contact your local telephone company to determine the maximum REN for your calling area.

Connection to the telephone network should be made by using standard modular telephone jacks, type RJ11. The plug and/or jacks used must comply with FCC Part 68 rules. If this telephone equipment causes harm to the telephone network, the telephone company will notify you in advance that temporary discontinuance of service may be required. But if advance notice isn't practical, the telephone company will notify the customer as soon as possible. Also, you will be advised of your right to file a complaint with the FCC if you believe it is necessary.

The telephone company may make changes in it's facilities, equipment, operations or procedures that could affect the proper functioning of your equipment. If they do, you will be notified in advance in order for you to make necessary modifications to maintain uninterrupted service.

This equipment may not be used on coin service provided by the telephone company. Connection to party lines is subject to tariffs.

If trouble is experienced with this unit, for repair or warranty information, please contact customer service at the address and phone listed below. If the equipment is causing harm to the network, the telephone company may request that you disconnect the equipment until the problem is resolved.

**DO NOT DISASSEMBLE THIS EQUIPMENT.** It does not contain any user serviceable components.

### **Limited Warranty:**

1. Warrantor: Dealer, Distributor, Retailer, and Manufacturer

2. Warranty and Remedy

We believe that this is a high quality product. Although we test all products for proper functionality, we cannot guaranty that there will never be a defective unit, or that a unit will function on every phone line and all communication equipment in existence. For this reason, it must be clear that the **Warrantors are not insuring your premises or guaranteeing that there will not be damage to your person or property if you use this Product.** If this warranty is unacceptable please return the unused Product for a full refund.

One Year Limited Warranty - Microtechnologies, Inc. warrants its products to be free from defects in material and workmanship under normal use for one year, and is not responsible for consequential damage or installation costs of any nature. In event that the Product does not conform to this Warranty at any time during the period of one year from original purchase date, Warrantor will repair the defect and return it to you at no charge. **Important: The Warranty is limited to replacement of the Product ONLY.** Secondly, because every phone line differs, we strongly encourage you to test this Product in its actual application. This should include a full test, involving the Product actually dialing to its designated location and someone verifying the proper response. This warranty shall terminate and be of no further effect at the time the Product is 1) damaged by extraneous causes such as fire, water, lightning, etc. or not maintained as reasonable and necessary: 2) modified: 3) improperly installed: 4) repaired by someone other than the Warrantor: 5) used in a manner or purpose for which the Product was not intended.

**WARRANTORS' OBLIGATION UNDER THIS WARRANTY IS LIMITED TO REPAIR OR REPLACEMENT OF THE PRODUCT ONLY. THIS WARRANTY DOES NOT COVER PAYMENT OR PROVIDE FOR THE REIMBURSEMENT OF PAYMENT FOR INCIDENTAL OR CONSEQUENTIAL DAMAGES.**

**It must be clear that the Warrantors are not insuring your premises or guaranteeing that there will not be damage to your person or property if you use this Product.** The Warrantors shall not be liable under any circumstances for damage to your person or property or some other person or that person's property by reason of the sale or use of this Product, or its failure to operate in the manner in which it is designed. The Warrantor's liability, if any, shall be limited to the original cost of the Product only. Use of this Product is at your own risk.

3. Procedures for obtaining performance for Warranty:

In the event that the Product does not conform to this Warranty, the Product should be shipped or delivered freight prepaid to a Warrantor with evidence of original purchase. If in any way you are not comfortable with the product or its Limited Warranty, we encourage you to return it unused for a full refund.

**Microtechnologies, Inc.**  
564 Berlin Turnpike  
Berlin, CT 06037  
1-860-829-2710 ph  
1-860-829-2712 fax  
[www.TemperatureGuard.com](http://www.TemperatureGuard.com)  
[sales@TemperatureGuard.com](mailto:sales@TemperatureGuard.com)