

# 4-20 mA Sensor Monitor & Alarm

Model VM500-4

Manual and Installation Instructions

---

<b>Index</b>	<b>Page</b>
General Description	3
Terminal Block Diagram	4
Installation	5
Accessing the 4-20 mA Sensor Monitor and Alarm	6
Programming Sensor Parameter Overview	7
Programming the Autodialer Functions	12
Using the 4-20 mA Sensor Monitor and Alarm	15
Callout Procedures and Alarm Conditions	17
Troubleshooting	19
Extended Battery information	20
Programming Table	21
FCC and	22
Warranty Information	23

## **General Description**

The Monitor & Alarm is a seven channel 4-20 mA sensor monitor and auto-dialer. The Monitor and Alarm also monitors two (2) dry contact inputs and power.

The Monitor and Alarm allows the user to program individual high and low limits, and a time delay for each sensor. When a sensor goes into an alarm condition, the Monitor and Alarm will call up to four programmable voice or pager numbers.

The Monitor and Alarm automatically converts the 4-20ma signal into the sensor's measurement parameter such as degrees, PSI or Lbs for displaying and reporting.

The Monitor and Alarm also monitors the power to which it is connected and will call its programmed telephone numbers if a power outage exists. Power failure calls occur after power has been out for more than five minutes.

The Monitor and Alarm monitors two dry contact inputs and make emergency calls if an input is closed longer than its programmed time delay.

The Monitor and Alarm will turn on its alarm relay and buzzer when any zone or input is in an alarm condition, or a dry contact input is closed. The alarm relay and buzzer is turned off by pressing the black button on the face of the dialer.

The Monitor and Alarm can be installed into new or existing systems. The input impedance of each is only 20 ohms and will not affect existing systems.

This remainder of the manual will refer to the 4-20ma Monitor and Alarm as Monitor.

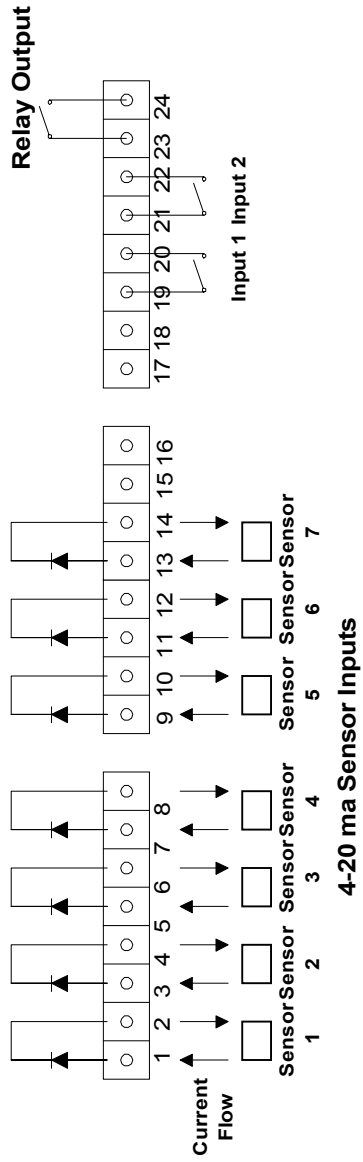

Sensor to Monitor Wiring Diagram

### **Installing the Monitor**

- 1 Select a location with access to power and a telephone line.
- 2 Mount the enclosure in the desired location.
- 3 Connect the phone line to an active phone jack.
- 4 Plug in the wall mount transformer into a power socket
- 5 Connect the wall mount transformer power jack to the Monitor.
- 6 For ease of wiring, remove the terminal blocks.
- 7 Wire the output of each sensor to the Monitor's terminal blocks. The Monitor can be installed in series with existing equipment such as chart recorders. See the Wiring Diagram.
- 8 Turn the power on by pressing the red button located to the left of the display on the front panel.

## Accessing the Monitor

- 1 From another phone line dial the number where the Monitor is located. The device will pick up after the programmed number of rings (Factory default is 1).
- 2 When prompted, enter the 4-digit PIN number (Factory default PIN number is 0000).
- 3 You will hear the Main Menu options:

Main Menu	
Option	Function
1	Status
2	Set Limits (Configure Sensor Characteristics)
3	Program
0	Exit (Hang Up)

## Programming Sensor Parameters Overview

For each sensor, three sets of parameters must be programmed.

- 1) Sensor Output Characteristics.
- 2) Sensor ID Message is recorded.
- 3) Sensor Alarm Limits are programmed.

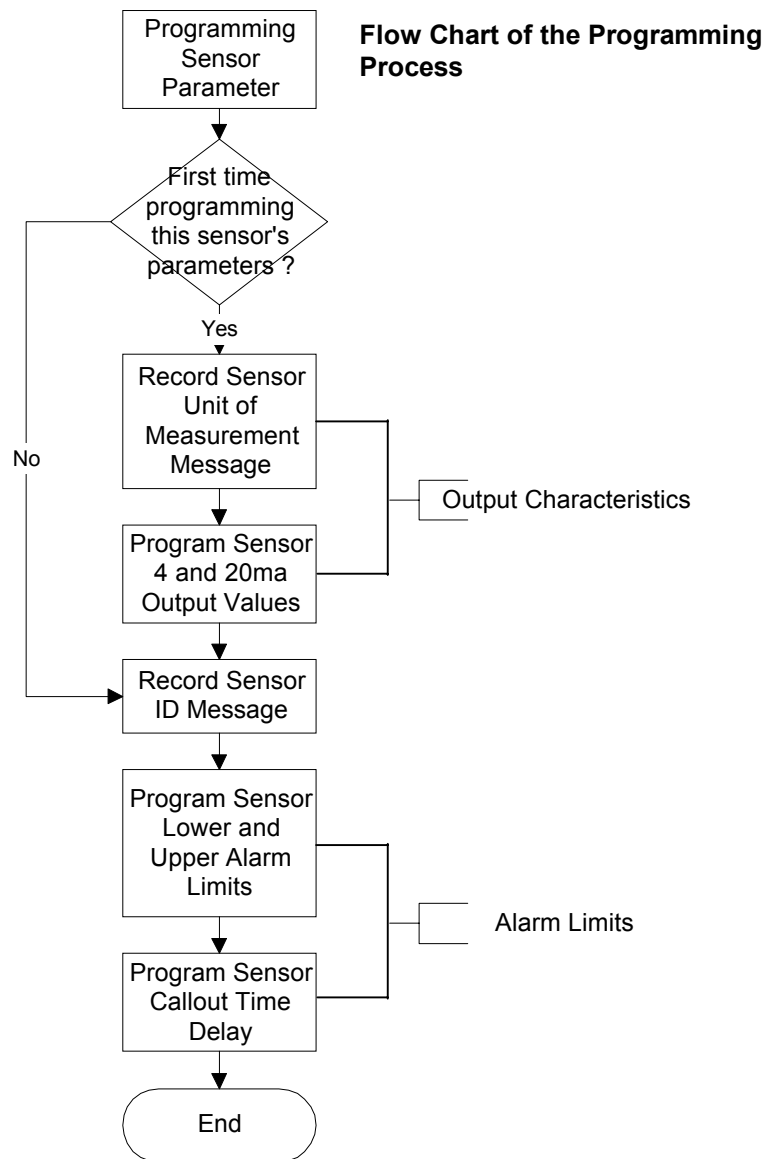

## Sensor Output Characteristics:

**Sensor's Unit of Measure Message.** When reporting a sensor's output value over the phone, the Monitor will play the unit of measurement message.

I.E. For a flow meter sensor with an output of gallons/minute, you could record "**GPM**". The Monitor would then report, "*Sensor 1, station flow meter, is 50 GPM.*"

**Sensor's 4 and 20 ma Output Values.** The sensor's output value at 4 and 20 ma must be programmed because the Monitor uses these values to calculate and display and report values in the sensor's unit of measurement.

I.E. If the output of the flow meter sensor at 4 ma is 0 GPM, and the output of the sensor at 20 ma is 100 GPM, then 0 and 100 is programmed for the 4 and 20 ma values.

## Sensor ID Message:

When reporting a sensor's output value over the phone, the Monitor plays the ID message to describe the sensor.

I.E. For the flow meter, you could record a message describing the sensor as **station 1 flow meter**. The Monitor would then use this message when reporting the output of the sensor. The message would be "Sensor 1, **station 1 flow meter**, is...."

## Sensor Alarm Parameters:

**Sensor low and high limits.** The low and high limits are programmed in the sensor's unit of measure. When the sensors output value exceeds either the high or low limit for longer than the programmed time delay, the Monitor will begin making telephone calls.

I.E. Limits for the flow sensor would be programmed in GPM.

**Sensor callout time delay.** A sensor must be out of limits for greater than the callout delay time before the Monitor will begin making telephone calls. This time can be used to prevent unnecessary alarms due to transient conditions.

I.E. For the flow sensor to generate an alarm after the flow has been out of limits for 5 minutes, program this value as 5.

## Programming the Sensor Parameters

- a) From the Main Menu, press 2 to Set Limits
- b) You will hear "Enter Sensor number"
- c) Enter the number of the sensor input you want to configure (1-7)
  - ▶ If you do not wish to program a sensor input press 0 to return to the Main Menu.

If this is the first time programming this sensor's parameters, you must program the Sensor Output Characteristics first. Once the parameters have been successfully programmed, this step can be skipped to more easily modify the Sensor Limits and Sensor ID Message.

## Programming the Sensor's Output Characteristics

### Recording the Sensor's Unit of Measurement Message

- a) You will hear "Sensor 1 unit of measure is.... ". *Initially the recorded sensor units message will be blank.*
- b) You will hear "Press 1 to change"
- c) Press **1** to record a new message. (Press 2 to skip to the next programming item or press 0 to program a different sensor)
- d) You will hear a beep. The system will record for 1 second.
- e) Say the desired sensor unit of measurement.
- f) You will hear another beep and recording will stop.
- g) You will hear the message you recorded.

### Programming the Sensor's 4 and 20 ma Output Values

The maximum programmable value is 2000 and the maximum difference between the 4 and 20 value is 1000. For values larger than 2000, divide by one thousand and enter those values, then adjust your unit of measure message to indicate a thousand multiplier.

I.E. if the flow sensor output at 4 ma is 3,000 GPM and at 20 ma is 5,000 GPM, divide both values by 1000 and record your unit of measurement message to be "*thousand GPM*". Enter 3 for the 4 ma value and 5 for the 20 ma value.

- a) You will hear "Enter value at 4 milliamps then press pound."
- b) Enter the sensor's value at 4 milliamps then press pound.
  - ▶ To enter a negative value, enter \* as the first digit.
  - ▶ To enter a value with a decimal place, use \* as the decimal place. For instance, to enter the value 1.23, enter 1\*23.
  - ▶ To stop monitoring this sensor, enter only #
- c) You will hear "Enter value at 20 milliamps then press pound."
- d) Enter the sensor's value at 20 milliamps then press pound.

- ▶ To enter a negative value, enter \* as the first digit.
- ▶ To enter a value with a decimal place use \* as the decimal place. For instance, to enter the value 1.23, enter 1\*23.

You will hear the values just programmed. If the values just entered are not valid you will hear "warning" and you will be prompted to re-enter the 4 and 20 ma values (returned to step a).

#### **Recording the Sensor's ID message**

- a) You will hear "Sensor 1 is " and the current recorded sensor ID. *Initially the sensor ID message will be blank.*
- b) You will hear "Press 1 to change"
- c) Press **1** to record a new message. (Press 2 to skip to the next programming item or press 0 to program a different sensor)
- d) You will hear a beep. The system will record for 2 seconds.
- e) Say the desired sensor ID message.
- f) You will hear another beep and recording will stop.
- g) You will hear the message you recorded.

#### **Programming the Sensor's Lower and Upper Alarm Limits**

- a) You will hear the low limit for that sensor (i.e. 45 GPM)
- b) You will hear "Press 1 to change"
- c) Press **1** to change the limit (Press 2 to skip to the next programming item and proceed to step g or press 0 to program a different sensor)
- d) You will hear "Enter number then press pound"
- e) Enter the value then press #.
  - ▶ To enter a negative value, enter \* as the first digit.
  - ▶ To enter a value with a decimal place use \* as the decimal place. For instance, to enter the value 1.23, enter 1\*23.
- f) You will hear the value you just entered (i.e. 55 GPM)
- g) You will hear the high limit for the selected sensor (i.e. 80 GPM)
- h) You will hear "Press 1 to change"
- i) Press **1** to change the limit (Press 2 to skip to the next programming item or press 0 to program a different sensor)
- j) You will hear "Enter number then press pound"
- k) Enter the value then press #.
  - ▶ To enter a negative value, enter \* as the first digit.
  - ▶ To enter a value with a decimal place use \* as the decimal place. For instance, to enter the value 1.23, enter 1\*23.
 You will hear the value you just entered (i.e. 85 GPM)

#### **Programming the Callout Time Delay**

- a) You will hear "Callout time delay is 0 minutes press 1 to change"
- b) Press 1 to change the time delay (Press 2 to skip)
- c) You will hear "Enter number then press pound"
- d) Enter the time delay in minutes (i.e. 15 for 15 minutes)

- ▶ The time delay range is 0 - 900 minutes.
- e) You will hear the value you just entered

### **Programming the Dry Contact Input Alarm Time Delay**

The dry contact input must be active for greater than the callout delay time before the Monitor will begin making telephone calls.

- 1 From the Main Menu, press 2 to set Limits
- 2 You will hear "*Enter Zone*"
- 3 Enter 8 to program Input 1 or 9 to program Input 2
- 4 You will hear "Input 1 Callout time delay is 0 minutes press 1 to change"
- 5 Press 1 to change the time delay (Press 2 to skip)
- 6 You will hear "Enter number then press pound"
- 7 Enter the time delay in minutes (i.e. 15 for 15 minutes)
  - ▶ The time delay range is 0 - 900 minutes.
- 8 You will hear the value you just entered

### **Changing the Sensor's Output Characteristics**

If it is necessary to make a change to the output characteristics, perform the following:

- a) From the Main Menu, press 2 to Set Limits
- b) You will hear "*Enter Sensor number*"
- c) Enter \*
- d) You will hear "*Enter Sensor number to change*"
- e) Enter the input number of the sensor you want to change (1-7) .

## Programming the Autodialer Functions

To access the Program Menu, press 3 at the Main Menu. You will hear the Program Menu options below.

Program Menu	
Option	Function
1	Program Primary Number
2	Program Secondary Number
3	Program Third Number
4	Program Fourth Number
5	Program Local ID Number
6	Record Unit ID Message
7	Program Number of Rings
8	Change PIN number
9	Program Reminder Calls
0	Exit (return to Main Menu)

NOT SPOKEN

### Programming Telephone/Pager Numbers

The Monitor stores up to 4 emergency telephone or pager numbers.

#### First Time Number Programming:

- 1 From the Program Menu, Select **1** for the primary number, **2** for the secondary number, **3** for the third number, or **4** for the fourth number.
- 2 You will hear *"Enter number then press pound"*
- 3a. For voice phone numbers enter the full phone number (**1 + area code if necessary**) followed by the # key.
- 3b. For pager numbers enter \* then enter the full pager number (**1 + area code if necessary**) followed by the # key.
4. You will hear the telephone number you just entered.
5. You will be automatically returned to the Program Menu

#### Note:

If an extra delay between digits is required, entering \* will provide a two second delay. Do not enter \* for the first digit unless programming a pager number.

#### To Change a Phone Number:

- 1 Select the appropriate number from the Program Menu
- 2 You will hear the telephone number for the selected recipient
- 3 You will hear *"Press one to change"*

- 4 Press **1** to make a change or **2** to return to the Program Menu
- 5 You will hear "*Enter number then press pound*"
- 6a. For voice phone numbers enter the full phone number (**1 + area code if necessary**) followed by the **#** key.
- 6b. For pager numbers enter \* then enter the full pager number (**1 + area code if necessary**) followed by the **#** key.
7. You will hear the telephone number you just entered.
8. You will be automatically returned to the Program Menu

**To Delete a Phone Number:**

- 1 Select the appropriate number from the Program Menu
- 2 You will hear the telephone number you selected
- 3 You will hear "*Press one to change*"
- 4 Press **1** to make a change
- 5 You will hear "*Enter number then press pound*"
- 6 Enter the **#** key
- 7 You will be automatically returned to the Program Menu

**Programming a Local Identification Number For Pagers**

The local ID number is printed on a pager's display, when calls are made to a pager. The ID number can be up to 20 digits long.

- 1 From the Program Menu, press **5** for the local ID
- 2 If this is the first time setup, go to step 6
- 3 You will hear the programmed number
- 4 You will hear "*Press one to change*"
- 5 Press **1** if you wish to make a change or press any other button to return to the Program Menu
- 6 You will hear "*Enter number, then press pound*"
- 7 Enter the number, followed by a **#**
- 8 You will hear the number you just entered.
- 9 You will be automatically returned to the Program Menu

**Recording a Personal Identification Message**

During Emergency Calls this message is played to identify the Monitor.

- 1 From the Program Menu, press **6** to record a message
- 2 If this is the first time setup, go to step 4
- 3 You will hear the recorded message
- 4 You will hear "*Press one to change.*"
- 5 Press **1** if you wish to make a change or press any other button to return to the Program Menu
- 6 You will hear a tone
- 7 Begin speaking after the tone. The Monitor will record for about 4 seconds
- 8 After 4 seconds you will hear the tone again, marking the end of your message

- 9 You will hear the message you recorded
- 10 You will be automatically returned to the Program Menu

### **Programming the Number of Rings**

The Monitor answers the telephone line after the programmed number of rings. Valid numbers of rings are 1 – 25.

- 1 From the Program Menu, press **7** to set the number of rings
- 2 You will hear the programmed number of rings
- 3 You will hear *"Press one to change."*
- 4 Press **1** if you wish to make a change or press any other button to return to the Program Menu
- 5 You will hear *"Enter number then press pound"*
- 6 Enter the number of rings, then press **#**
- 7 You will hear the number of rings you entered
- 8 You will be automatically returned to the Program Menu

### **Programming PIN Numbers**

The Monitor uses a 4-digit PIN numbers (0000-9999) to identify valid users. **PIN numbers must be 4 digits and must not include a # sign.**

- 1 From the Program Menu, press **8** to change the "Full Access" PIN or press the **#** key to change the "Acknowledge Only" PIN.
- 2 You will hear the programmed PIN number
- 3 You will hear *"Press one to change."*
- 4 Press **1** to make a change or **2** to return to the Program Menu
- 5 You will hear *"Enter your PIN number"*
- 6 Enter a four digit number
- 7 You will hear the PIN number you just entered
- 8 You will be automatically returned to the Program Menu

### **Programming a Reminder Call**

The Monitor can place "reminder calls" even after Emergencies have been acknowledged, if zones are still out-of-limits or inputs are not back to their normal state after a set period time. This enables the user to receive more emergency calls in cases where problems have not been fixed within a reasonable period of time. The reminder call is not enabled by default and must be activated by the user. The reminder call delay is a programmable value from 0 to 900 minutes.

- 1 From the Program Menu, press **9**
- 2 You will hear "Alarm Reminder is Off"
- 3 You will hear *"Press one to change."*
- 4 Press **1** if you wish to enable reminder calls , or any other key to return to the Program Menu.
- 5 You will hear "Alarm Reminder is On"
- 6 You will hear *"Callout time delay is xx minutes press 1 to*

- change" (Default value is 60 minutes)
- 7 Press 1 to make a change or press any other button to not make a change
- 8 You will hear "Enter number then press pound"
- 9 Enter the time delay in minutes (i.e. 120 for 2 hours)
- 10 You will hear the value you just entered
- 11 You will be returned to the Set Limits Menu

## Using the Monitor

### Interpreting the Display

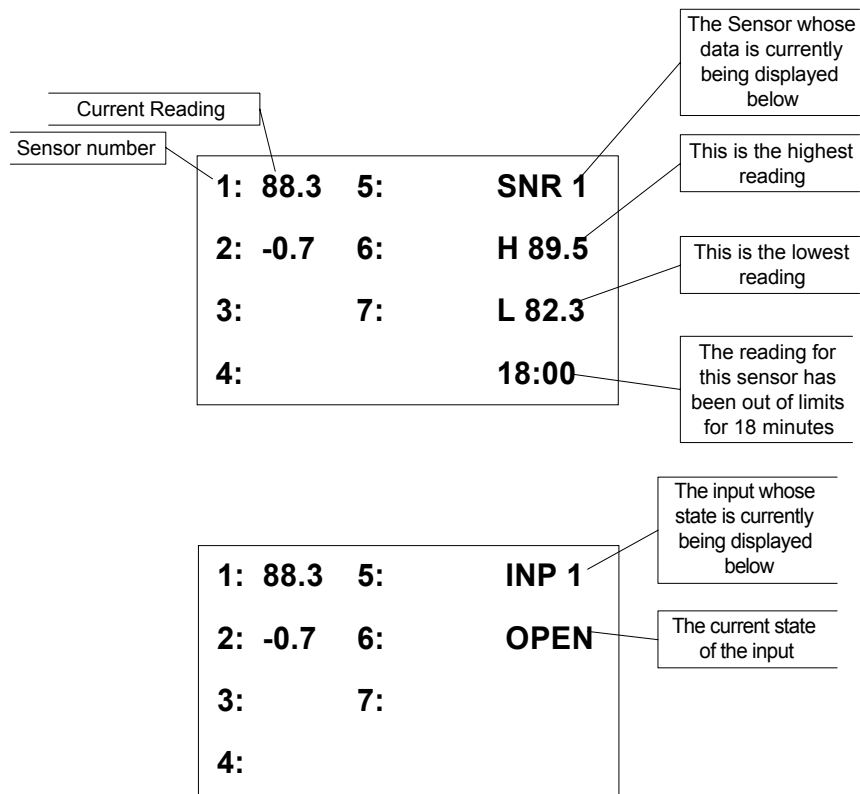

### **Clearing High and Low Values Locally**

High and low values can be cleared by holding the black pushbutton down for at least 5 seconds while that sensors data is being displayed.

### **Checking Sensor Values Remotely**

- 1 Call the Monitor
- 2 Enter you PIN number
- 3 From the main menu press **1**
- 4 You will hear "*Enter Sensor number*"
- 5 Enter the number of the sensor you wish to hear (i.e. 1)
- 6 You will hear the current sensor value and its highest and lowest reading, and how long the sensor has been out of limits in minutes.

### **Clearing High and Low Values Remotely**

- 1 Call the Monitor
- 2 Enter you PIN number
- 3 From the main menu press **1**
- 4 You will hear "*Enter Sensor number*"
- 5 Press **#**
- 6 You will hear "Enter Sensor number to Change"
- 7 Enter the number of the sensor whose data you wish to reset.

### **Checking the Status of the Inputs Remotely**

- 1 Call the Monitor
- 2 Enter you PIN number
- 3 From the main menu press **1**
- 4 You will hear "*Enter Sensor number*"
- 5 Enter **8** to check input 1 or **9** to check input 2
- 6 You will hear the status of the input, unless power is out, and the status of the power.

### **When does the Monitor call?**

The Monitor will callout when a sensor has been out of limits for greater than the programmed time delay. Or, if a sensor opens after having read a value.

The Monitor will callout when a dry contact input is active for greater than the programmed time delay.

The Monitor will callout when power has been out for greater than 5 minutes.

### **What happens when there is an alarm condition?**

- 1 The alarm relay and buzzer will be energized.
- 2 The Monitor will begin calling all programmed telephone numbers starting with the primary.
- 3 The Monitor will wait for a person to stop speaking or any outgoing message to stop.
- 4 The Monitor will play the personal identification message.
- 5 The Monitor will report any alarm conditions (i.e. "*sensor 2 pressure sensor is 44 PSI*").
- 6 The Monitor will ask for the PIN.
- 7 Once the PIN number has been entered, the Monitor will not call again because the current alarm condition has been acknowledged. The alarm relay and buzzer will not turn off until the black button on the Monitor has been pressed.

### **What happens when the Monitor calls a pager?**

- 1 The Monitor will print the Local Identification number on the pager screen.
- 2 The Monitor will continue to call the pager until either:
  - The alarm condition goes away OR
  - The Monitor is called and the PIN number is entered

### **Canceling Alarm Conditions Locally**

To cancel an alarm condition locally, push the black button on the left side of the Monitor. The alarm relay will de-energize, and the Monitor will stop making emergency phone calls for this alarm condition.

### **Connecting the Monitor to a Phone Line which has a fax or answering machine connected to it**

Program the Monitor to answer after one more ring than the other device. This allows the other device to always answer first. To call and access the Monitor

- 1 Dial the phone number
- 2 Hang up one ring before the other device answers.
- 3 Wait no longer than 30 seconds, then dial the phone number again.

4 The Monitor and Alarm will answer.

For Example:

*A fax machine on the same line as the Monitor is set to answer after 4 rings. The Monitor is programmed to answer after 5 rings. To access the Monitor, dial the number, let it ring three times, then hang up. Wait 20 seconds and call again. After two rings, the Monitor will answer.*

## Troubleshooting

### **Verifying telephone communication**

To verify telephone communications, perform the following test.

- Using another phone line, call the Monitor and verify that it answers the phone.
- Verify at least one programmed telephone number.
- Hang up.
- Remove the power plug from the back of the 4-20 mA Sensor Monitor and Alarm.
- Wait Five minutes.
- The 4-20 mA Sensor Monitor and Alarm will call to alert you that the power is out.
- Watch the display and note any messages present.

### **If the Monitor does not answer the phone**

Verify that the phone line is working. Connect a standard phone to the line intended for the Monitor. Verify that there is a dial tone.

Check that the phone line is plugged in securely.

Verify that the Monitor is powered up and the status light is blinking.

### **If the Monitor does not call out**

Perform the telephone communication verification procedure.

Connect a phone to the line intended for the Monitor. Verify that there is a dial tone.

Check that the phone line is plugged in securely

Verify that the Monitor is powered up and the status light is blinking

Verify that the Monitor is programmed correctly. Call up the Monitor and verify the programmed phone numbers and limits.

### **Verifying sensor readings**

To verify that the Monitor is reading the 4 to 20 mA sensor correctly perform the following operation:

- Turn off the unit.
- Make a connection across Input 2.
- Hold down the black pushbutton.

- Turn on the unit.
  - The unit will boot up in a test mode.
  - All values displayed are mA values.
- Verify that the unit is reading the correct mA value.

### **Optional 20 / 30 Hour Extended Batteries**

If your unit has been ordered with an extended battery, it is installed at the factory. These batteries are trickle charged and can take up to a week to reach full capacity. The battery is charging whenever the monitor is powered on.

To simplify programming, fill in this table

<b>Sensor Input Number</b>	<b>Unit of Measurement Message</b>	<b>Output Value at 4 ma</b>	<b>Output Value of 20 ma</b>	<b>ID Message</b>
1				
2				
3				
4				
5				
6				
7				

#### FCC PART 68 INFORMATION

This equipment complies with Part 68 of the FCC Rules. The FCC Part 68 Label is located on the bottom of the unit. This label contains the FCC Registration Number and Ringer Equivalence Number (REN) for this equipment. If requested, this information must be provided to your telephone company.

The REN is useful to determine the quantity of devices you may connect to your telephone line and still have all of those device ring when your telephone number is called. In most, but not all areas, the sum of the RENs of all devices connected to one line should not exceed five (5.0). To be certain of the number of devices you may connect to your line, as determined by the REN, you should contact your local telephone company to determine the maximum REN for your calling area.

Connection to the telephone network should be made by using standard modular telephone jacks, type RJ11. The plug and/or jacks used must comply with FCC Part 68 rules. If this telephone equipment causes harm to the telephone network, the telephone company will notify you in advance that temporary discontinuance of service may be required. But if advance notice isn't practical, the telephone company will notify the customer as soon as possible. Also, you will be advised of your right to file a complaint with the FCC if you believe it is necessary.

The telephone company may make changes in it's facilities, equipment, operations or procedures that could affect the proper functioning of your equipment. If they do, you will be notified in advance in order for you to make necessary modifications to maintain uninterrupted service.

This equipment may not be used on coin service provided by the telephone company. Connection to party lines is subject to tariffs.

If trouble is experienced with this unit, for repair or warranty information, please contact customer service at the address and phone listed below. If the equipment is causing harm to the network, the telephone company may request that you disconnect the equipment until the problem is resolved.

**DO NOT DISASSEMBLE THIS EQUIPMENT.** It does not contain any user serviceable components.

## **Limited Warranty:**

1. Warrantor: Dealer, Distributor, Retailer, and Manufacturer
2. Warranty and Remedy

We believe that this is a high quality product. Although we test all products for proper functionality, we cannot guaranty that there will never be a defective unit, or that a unit will function on every phone line and all communication equipment in existence. For this reason, it must be clear that the **Warrantors are not insuring your premises or guaranteeing that there will not be damage to your person or property if you use this Product.** If this warranty is unacceptable please return the unused Product for a full refund.

**One Year Limited Warranty** - Microtechnologies, Inc. warrants its products to be free from defects in material and workmanship under normal use for one year, and is not responsible for consequential damage or installation costs of any nature. In event that the Product does not conform to this Warranty at any time during the period of one year from original purchase date, Warrantor will repair the defect and return it to you at no charge. **Important: The Warranty is limited to replacement of the Product ONLY.** Secondly, because every phone line differs, we strongly encourage you to test this Product in its actual application. This should include a full test, involving the Product actually dialing to its designated location and someone verifying the proper response.

This warranty shall terminate and be of no further effect at the time the Product is 1) damaged by extraneous causes such as fire, water, lightning, etc. or not maintained as reasonable and necessary: 2) modified: 3) improperly installed: 4) repaired by someone other than the Warrantor: 5) used in a manner or purpose for which the Product was not intended.

**WARRANTORS' OBLIGATION UNDER THIS WARRANTY IS LIMITED TO REPAIR OR REPLACEMENT OF THE PRODUCT ONLY. THIS WARRANTY DOES NOT COVER PAYMENT OR PROVIDE FOR THE REIMBURSEMENT OF PAYMENT FOR INCIDENTAL OR CONSEQUENTIAL DAMAGES.**

**It must be clear that the Warrantors are not insuring your premises or guaranteeing that there will not be damage to your person or property if you use this Product.** The Warrantors shall not be liable under any circumstances for damage to your person or property or some other person or that person's property by reason of the sale or use of this Product, or its failure to operate in the manner in which it is designed. The Warrantor's liability, if any, shall be limited to the original cost of the Product only. Use of this Product is at your own risk.

3. Procedures for obtaining performance for Warranty:

In the event that the Product does not conform to this Warranty, the Product should be shipped or delivered freight prepaid to a Warrantor with evidence of original purchase. If in any way you are not comfortable with the product or its Limited Warranty, we encourage you to return it unused for a full refund.

**Microtechnologies, Inc.**  
564 Berlin Turnpike  
Berlin, CT 06037  
1-860-829-2710 ph  
1-860-829-2712 fax  
[www.TemperatureGuard.com](http://www.TemperatureGuard.com)  
[sales@TemperatureGuard.com](mailto:sales@TemperatureGuard.com)

Rev 50403