



Microtechnologies, Inc.
44 Washington Ave., Suite 8
Berlin, CT 06037
860-829-2710 (voice)
860-356-4823 (fax)
www.TemperatureGuard.com

MA412 Temperature Monitor and Alarm

Operation

The MA412 is a temperature monitor and alarm. The microprocessor based control simultaneously monitors up to eight temperature sensors. Each sensor has a programmable upper and lower temperature limit, and a defrost time delay. The isolated, normally open contacts of an alarm relay can be wired to existing alarm panels or other signaling equipment.

Reading the Display

OK indicates that a sensor is connected to this channel. Read when power is first applied, e.g. S1: OK

TOL indicates that the sensor has detected an Out of Limit condition continuously for that time.

The (> or <) indicates that the sensor has continuously detected an out of limit condition greater or less than the programmed value.

LEDs There are eight red LEDs on the control, one for each alarm relay. The LEDs are on when the alarm relay is on.

Mode Switching

The MA412 can be set to monitor either four or eight temperature sensors. To set the desired mode, press the [Enter] button at any time. The display will toggle between monitoring 4 and 8 temperature sensors when [Up] or [Down] is pressed. Press [Enter] to set mode and advance to the temperature sensor limits programming.

Monitoring 1 to 4 Temperature Sensors

When monitoring one to four temperature sensors, two alarm relays are used for each sensor. One alarm relay turns on when the temperature exceeds the upper temperature limit and the second alarm relay turns on when the temperature exceeds the lower temperature limit. In both cases, the temperature has to be out of limits longer than the programmed defrost time delay.

Monitoring 5 to 8 Temperature Sensors

When monitoring five to eight temperature sensors, one alarm relay is used for each sensor. The alarm relay turns on when the temperature exceeds either the upper or lower temperature limit. The alarm relay will turn on after exceeding the temperature limit longer than the programmed defrost time delay.

In both modes, the alarm relay will remain on until the temperature goes back within limits or it is cleared.

Note: the MA412 will only return to the monitoring mode after the last parameter is entered.

Selecting the Temperature Measurement Units

Once the number of temperature sensors to monitor has been programmed, the temperature measurement units are programmed. The default measurement unit is °F and the display will show:

Units F

Press the [UP] button to toggle between °F and °C.
Press the [Enter] button to continue to program temperature limits.

Programming the Temperature Limits and Defrost Time Delay

To access the program mode, press the Enter button. Sensor 1 to sensor 8 limits will be programmed as follows:

Sensor x **Upper Limit** (°F) - **(UL)** Max limit is 300°F
Sensor x **Lower Limit** (°F) - **(LL)** Min limit is 147 °F
Sensor x **Defrost Time Delay** (minutes) - **(DTD)**

After setting the operating mode, Sensor 1 Upper Limit is displayed. In the example below, the upper limit is shown as 50 °F.

Sensor 1 UL 50

1. To increment the upper limit, press the [UP] button.
2. To decrement the upper limit, press the [DWN] button.
3. To save the limit, press [ENTER]. When the [ENTER] button is pressed, the limit is saved and sensor 1 Lower Limit is displayed.

In this example, the lower limit is shown as 35 °F.

Sensor 1 LL 35

1. To increment the limit, press the [UP] button.
2. To decrement the limit, press the [DWN] button.
3. To save the limit, press [ENTER]. When the [ENTER] button is pressed, the limit is saved and sensor 1 Defrost Time Delay is displayed.

In the example, Sensor 1's defrost time delay is shown as 15 minutes. The MA412 will close the alarm relay when the temperature has been out of limits for greater than 15 minutes. The DTD should be programmed long enough to avoid nuisance calls, but short enough to prevent spoilage.

Sensor 1 DTD 15

1. To increment the time, press the [UP] button.
2. To decrement the time, press the [DWN] button.
3. To save the time, press [ENTER]. When the [ENTER] button is pressed, the sensor 2 parameters are displayed. This sequence is repeated for all sensors.

Press the [Clear] button to bypass a sensor.

The MA412 will go back to the monitoring mode only after all sensors are programmed

Field Temperature Calibration/Correction

A one point field calibration/correction can be performed for each sensor to remove any error introduced by wire lead length. It is recommended that calibration be performed after the temperature reading made by the MA412 has stabilized. This temperature reading is then corrected to a know standard. To calibrate a sensor:

1. Wait until the sensor to be calibrated is displayed.
2. Simultaneously press down and hold the [UP] and [DOWN] pushbuttons until "Cal Mode" is displayed. Release the [UP] and [DOWN] pushbuttons (approx 4 seconds).
3. Press the [UP] or [DWN] button until the temperature displayed on the MA412 equals the temperature measured by the standard.
4. Press the [ENTER] key to save the calibration and return to the monitoring mode.

Calibration is being performed on Sensor 1. The current temperature measurement is continuously displayed (i.e.45 °F.)

S1 45 Cal Mode

Clearing Alarms

To acknowledge an alarm and turn off the alarm relay (and optional buzzer) press pushbutton on the top edge of the enclosure or the [CLEAR] button on the circuit board while *the sensor of interest is being displayed*. The sensor will continue to be monitored.

S3 > 45 TOL 5

In this example, Sensor 3 is in alarm and its alarm relay is closed (red LED is ON). While the sensor 3 data is displayed, press the [CLEAR] button. The relay will turn off.

Monitoring 8 Sensors

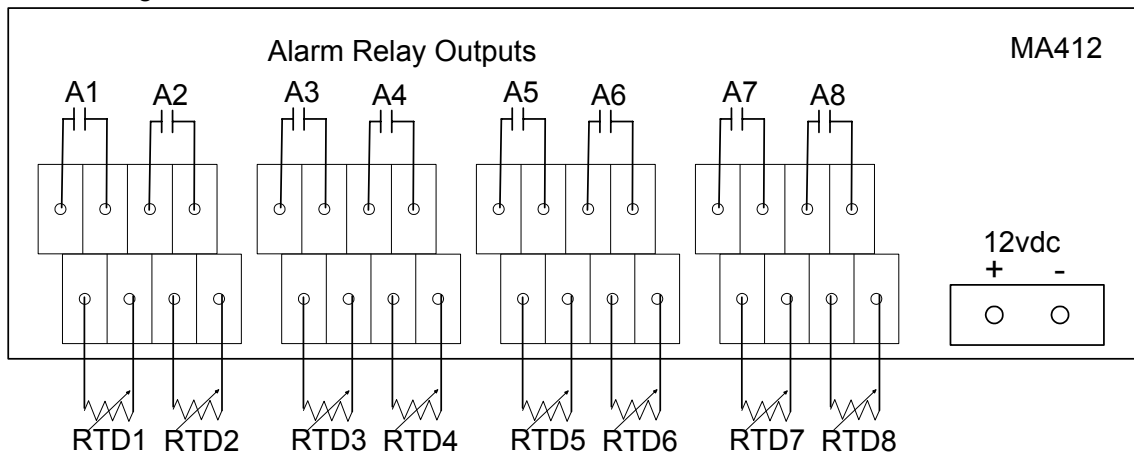

Monitor 5 to 8	
Alarm Relay	Function
A1	RTD 1 Upper or Lower Limit or Open or Short Circuit
A2	RTD 2 Upper or Lower Limit or Open or Short Circuit
A3	RTD 3 Upper or Lower Limit or Open or Short Circuit
A4	RTD 4 Upper or Lower Limit or Open or Short Circuit
A5	RTD 5 Upper or Lower Limit or Open or Short Circuit
A6	RTD 6 Upper or Lower Limit or Open or Short Circuit
A7	RTD 7 Upper or Lower Limit or Open or Short Circuit
A8	RTD 8 Upper or Lower Limit or Open or Short Circuit

Monitoring 1 to 4 Temperature Sensors

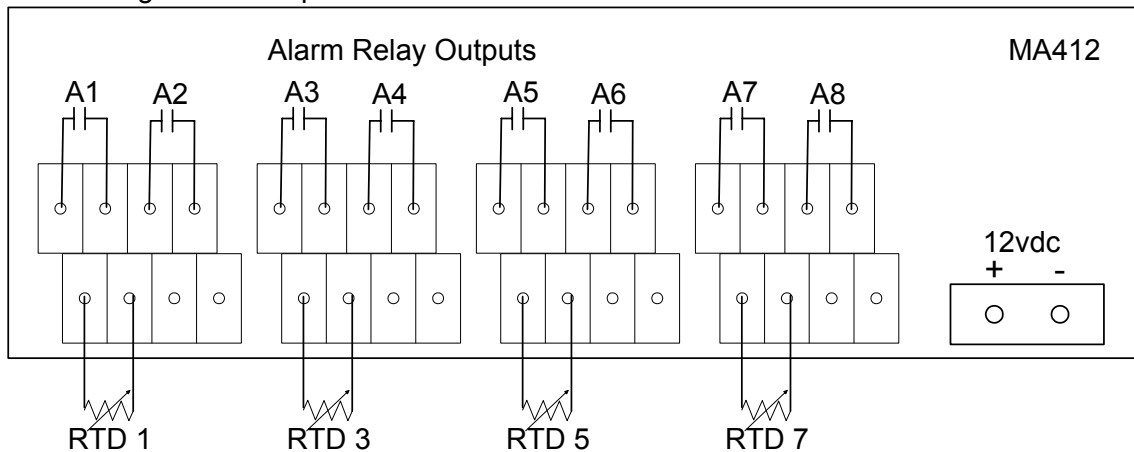

Wire the four sensors to RTD inputs 1, 3, 5, 7

Monitor 1 to 4

Alarm Relay	Function
A1	RTD 1 Upper Limit or Open Circuit
A2	RTD 1 Lower Limit or Short Circuit
A3	RTD 2 Upper Limit or Open Circuit
A4	RTD 2 Lower Limit or Short Circuit
A5	RTD 3 Upper Limit or Open Circuit
A6	RTD 3 Lower Limit or Short Circuit
A7	RTD 4 Upper Limit or Open Circuit
A8	RTD 4 Lower Limit or Short Circuit

Wiring diagram for Cryogenic Temperature Sensors ACI/1K-3W-LTS

